

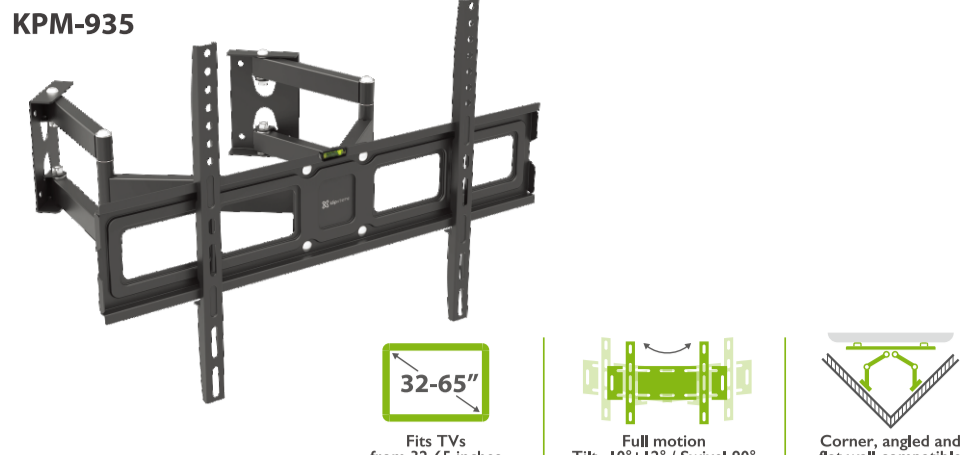

Articulated corner or flat wall Mount for LED/LCD and plasma displays

KPM-935



Introdução:

Thank you for purchasing the KPM-935 Articulated flat wall and corner mount. This product is shipped with all proper installation hardware and components. Upon opening the box, make sure that none of these parts are missing and/or damaged before beginning installation.

I. Hardware kit

Label	Image	Item	Quantity
1		Wall mount assembly	1
2		Screen Mount arm	2
A1		TV leg bolt	2
A2		TV corner anchor	4
A3		TV metal washer	8
B1		Bubble level	1
B2		Plastic spacer	4
B3		Metal washer	4
B4		20mm spacer	4
C		P16x20mm screw	4
D1		P16x25mm screw	4
D2		P16x50mm screw	4
E		P16x20mm screw	4

**NOTE:** The hardware provided is VESA compliant matching the hole specifications adopted by the most widely known TV screens and monitors. However, certain devices may require different sizes of screws and/or washers to attach the back panel to the mount. Any additional hardware needed must be supplied separately by the user.

IMPORTANT:

At least two qualified people should perform the assembly procedure. Personal injury and/or property damage can result from dropping or mishandling the display.

Maximum flat or curved panel weight:

The wall structure must be capable of supporting at least five times the weight of the flat panel. Otherwise, the wall structure must be reinforced.

2. WARNING!

- Prior to installing this product, you must read all instructions thoroughly. Keep these installation instructions in an easily accessible location for future reference.
- Safety measures must be practiced at all times during the assembly of this product. Use proper safety equipment and tools for the assembly procedure to prevent personal injury.
- Klip Xtreme does not warrant against damage caused by the use of any Klip Xtreme mounts for purposes other than those for which it was designed or damage caused by unauthorized attachments or modifications, and is not responsible for any damages, claims, demands, suits, actions or causes of action of whatever kind resulting from, arising out of or in any manner relating to any such use, attachments or modifications.

3. Installation of the mount arms to the rear panel of the screen

- Place your flat panel screen-side down on a soft, even surface, and identify the threaded mounting points that are located on the back of the flat panel.
- Determine the correct screw size by carefully inserting a straw or toothpick, and mark the depth of the mounting point. Please note that not all the hardware included will be used or that user-supplied hardware may be needed in certain cases.



- Com o suporte totalmente estendido, faça todas as conexões necessárias e **CAUTION:** Verifique a adequada thread engagemnt of the screw/spacer combination on fios ao longo dos braços e atrás das placas traseiras, para obter uma instalação adequada. A lack of sort will not hold the TV and too long will damage the TV, e de aparência profissional.
- Ajuste os ângulos de inclinação e de giro na melhor posição de visualização.



- Attach the mount arms to the flat panel by aligning the holes with the threaded inserts on the back of the display.

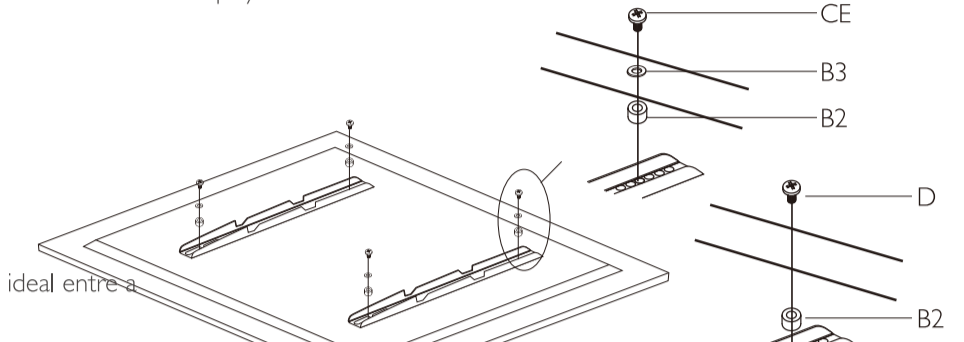

- Conduza empurrando ou puxando os braços de articulação até que a distância ideal entre a parede e a tela for atingida.



Standard flat panelmount installation

If flat panel has an irregular back or recessed mounting points, spacers must be placed on the mounting arm and the flat panel to compensate the difference in depth.

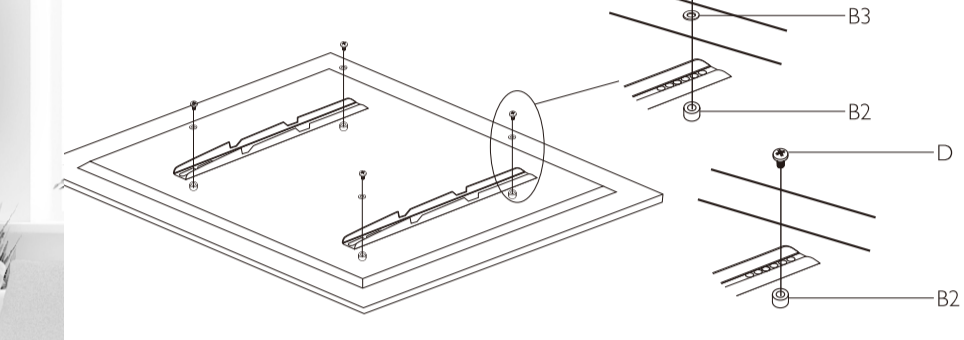

Screen with a curved back or recessed mounting points



- Utilize os parafusos recomendados e as aruelas retangulares para fixar os dois braços à tela. Tenha cuidado para não apertar demais os parafusos.

4. Instalação do suporte na parede

Antes de instalar este produto, você deve ler todas as instruções cuidadosamente. Mantenha estas instruções de instalação em um local de fácil acesso para referências futuras.

Medidas de segurança devem ser praticadas em todos os momentos durante a montagem deste produto. Use equipamentos de segurança e ferramentas adequadas para o procedimento de montagem para evitar lesões pessoais.

A Klip Xtreme não se responsabiliza por danos causados pelo uso de qualquer suporte Klip Xtreme para fins diferentes daqueles para os quais foi projetado, ou danos causados por acessórios ou modificações não autorizadas, e não se responsabiliza por danos, reclamações, demandas, ações ou causas de ação de qualquer tipo resultantes, decorrentes ou de qualquer forma relacionadas a tal uso destes acessórios ou modificações.

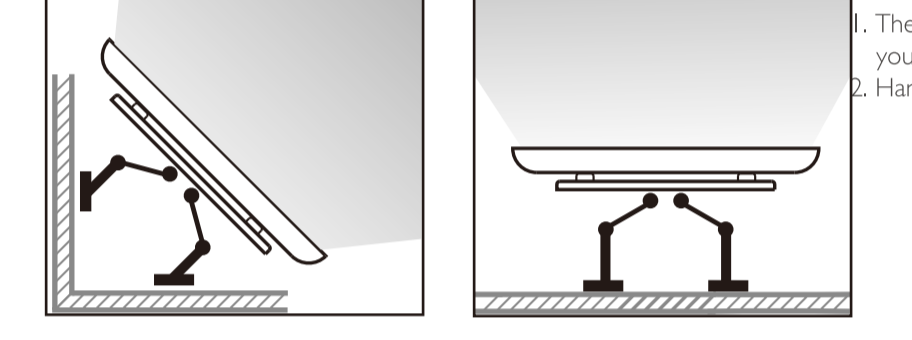

5. Final assembly

- The flat panel must be lifted carefully by two people in order to attach it to the wall mount you just installed.
- Hang both arms by aligning the top and bottom hooks on the horizontal rails of the mount.

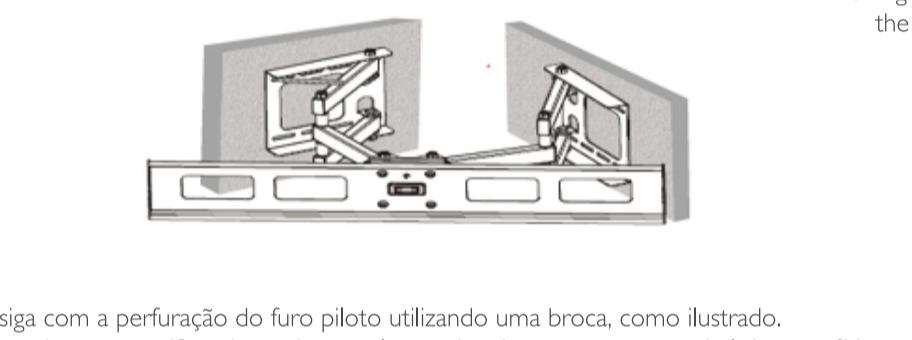

Solid concrete mounting

3. Tighten the screws in both mounting arms to secure the display onto the wall, as shown in the figure below.

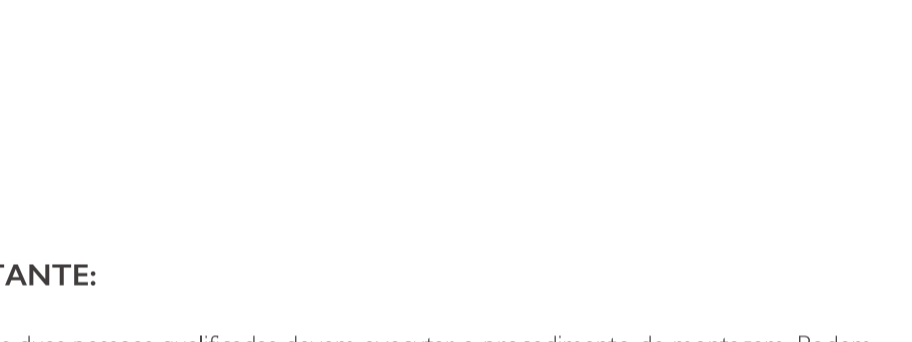

- Coloque o nível de bolha no centro da placa de TV horizontal. Se a bolha estiver centralizada entre as linhas, significa que o suporte está posicionado corretamente na superfície.

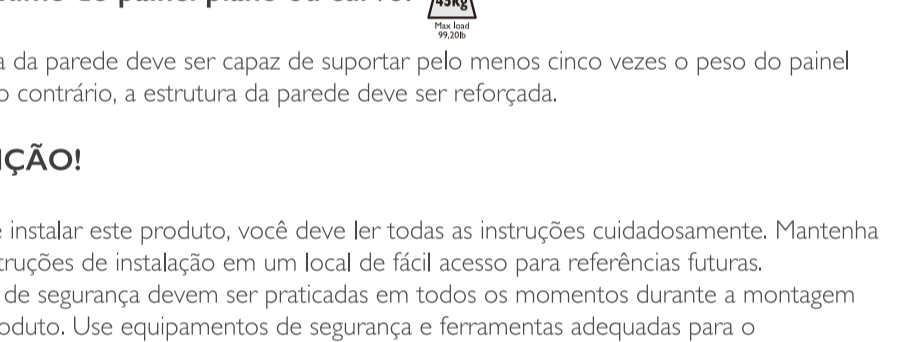

- Prossiga com a perfuração do furo piloto utilizando uma broca, como ilustrado.
- Inserir as âncoras retentadoras e aruelas, e introduzi-las firmemente na parede, como ilustrado abaixo.

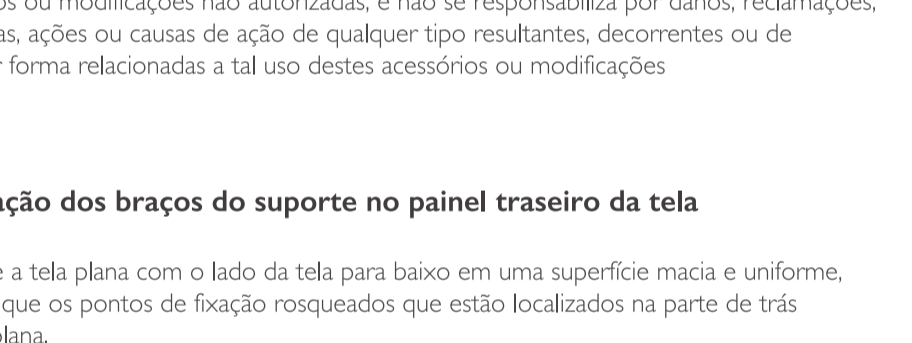

2.91inch collapsed

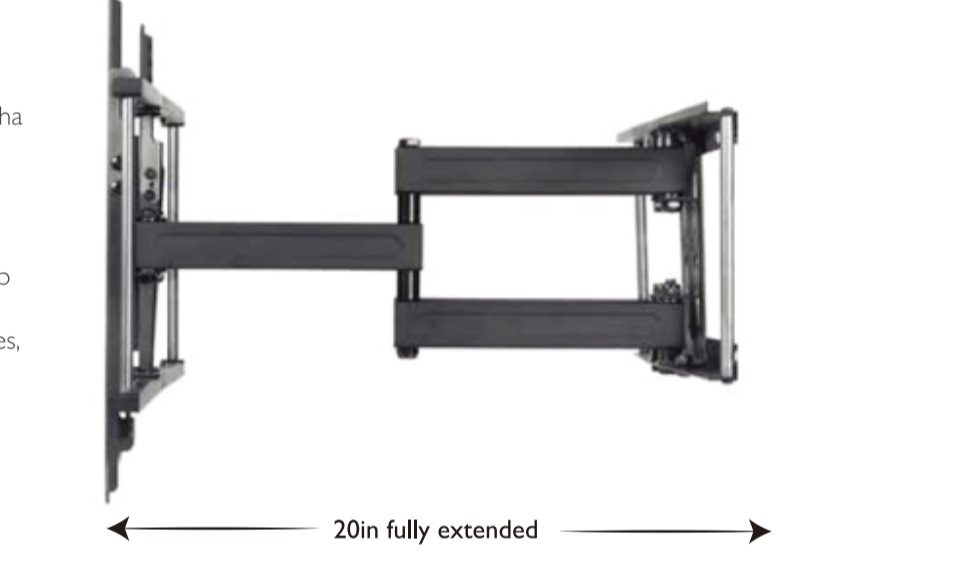

20inch fully extended



- Use the recommended screws and rectangular washers to secure both arms to the display. Be careful not to over-tighten the screws.

4. Wall mount installation

- Use the mount's back plates as a template to mark the mounting positions on the wall. **Note:** The mount is great for corner installation, but it can also be mounted on straight walls.

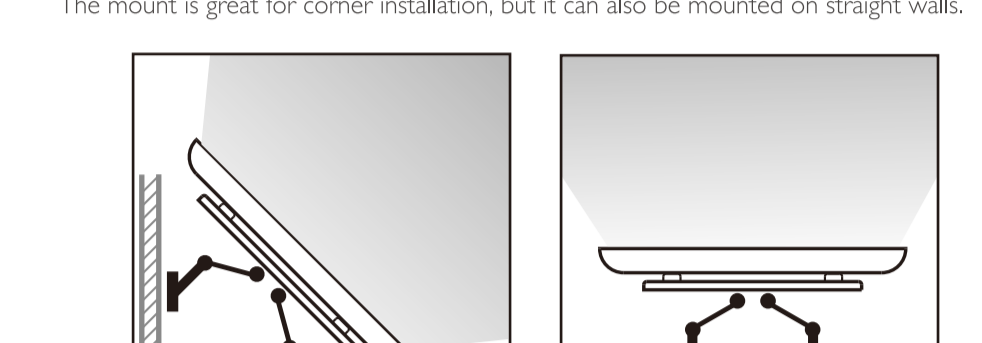

- Attach the bubble level right at the center of the horizontal TV plate. If the bubble is centered between the lines, it means that the mount is correctly positioned on the surface.

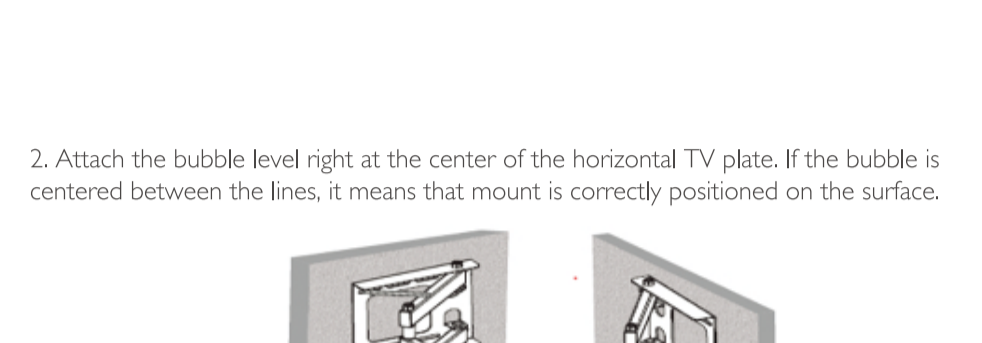

- Proceed to drill the pilot holes using a drill bit, as illustrated.
- Insert the anchors making sure they are seated flush with the surface.
- Insert leg bolts and washers, and drive them firmly into the wall, as shown below.

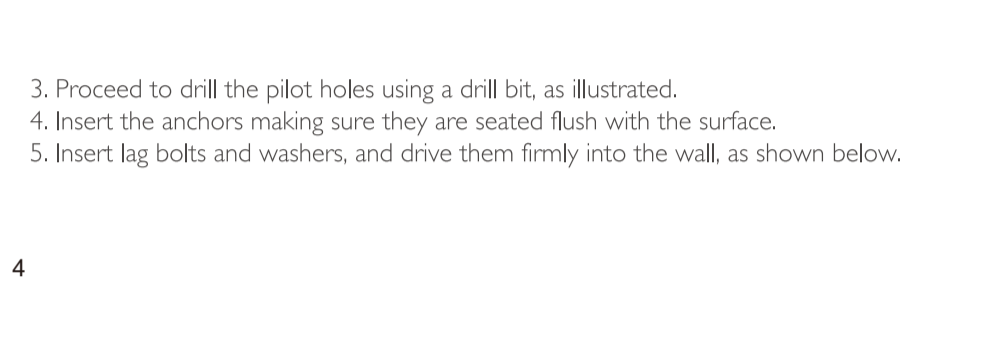

- With the mount fully extended, make all the necessary connections and route the wires along the arms and behind the back plates, for a finished and professional looking installation.
- Adjust the tilt and swivel angles in the best viewing position.

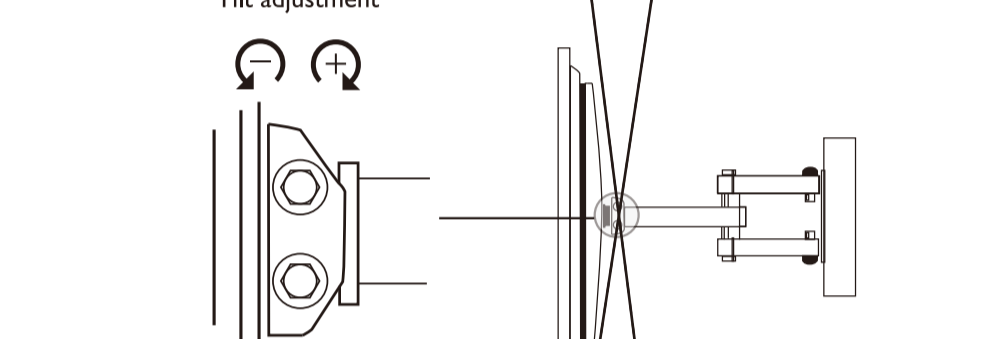
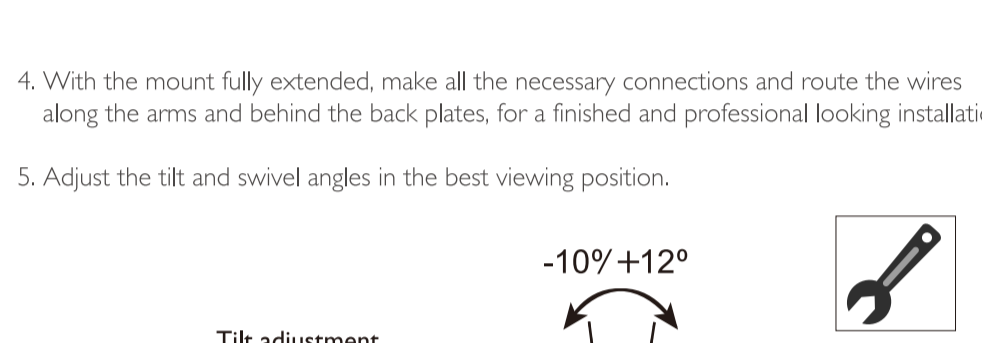

6. Finish by pushing or pulling the articulating arms until the optimal distance from the wall is reached

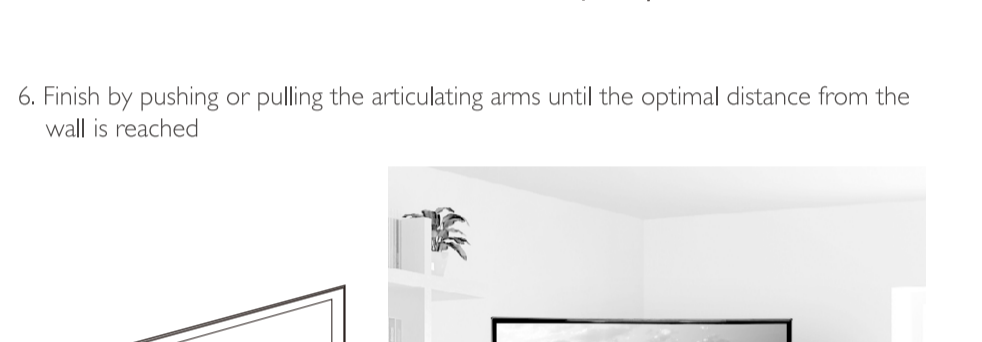

7. Final assembly

- The flat panel must be lifted carefully by two people in order to attach it to the wall mount you just installed.
- Hang both arms by aligning the top and bottom hooks on the horizontal rails of the mount.

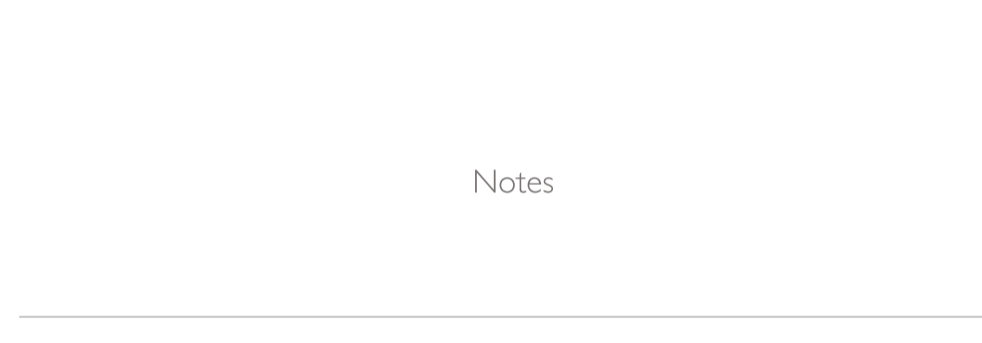

2.91inch collapsed



20inch fully extended

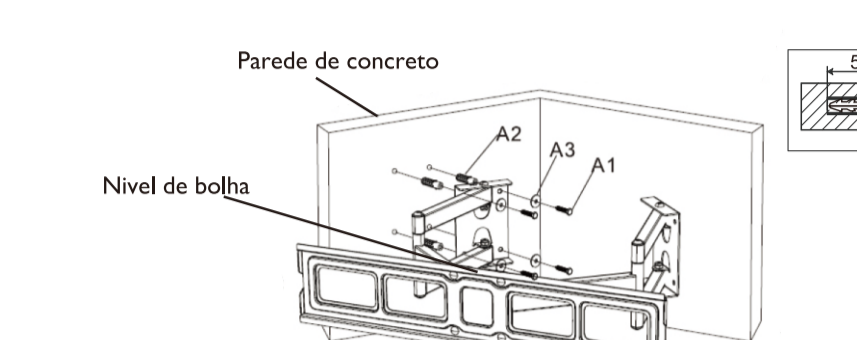

5. Montagem final

- A tela plana deve ser levantada cuidadosamente por duas pessoas a fim de conectá-la ao suporte de parede que você acabou de instalar.
- Pendure os dois braços alinhando os ganchos superiores e inferiores nos trilhos horizontais do suporte.



3. Aperte os parafusos em ambos os braços de montagem para fixar a tela na parede, conforme mostrado na figura abaixo.

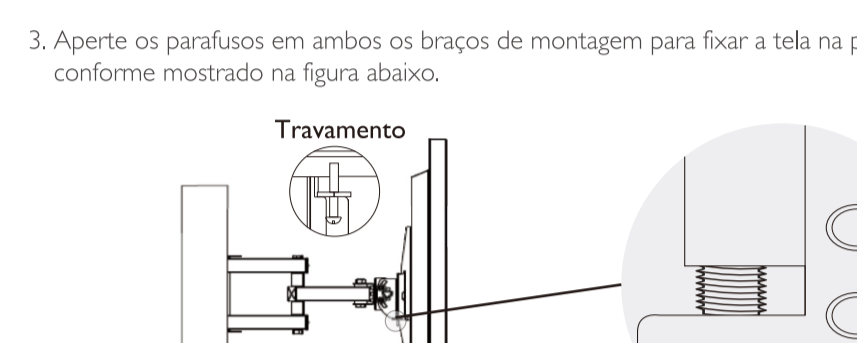

Instalação na parede de concreto

3. Aperte os parafusos em ambos os braços de montagem para fixar a tela na parede, conforme mostrado na figura abaixo.

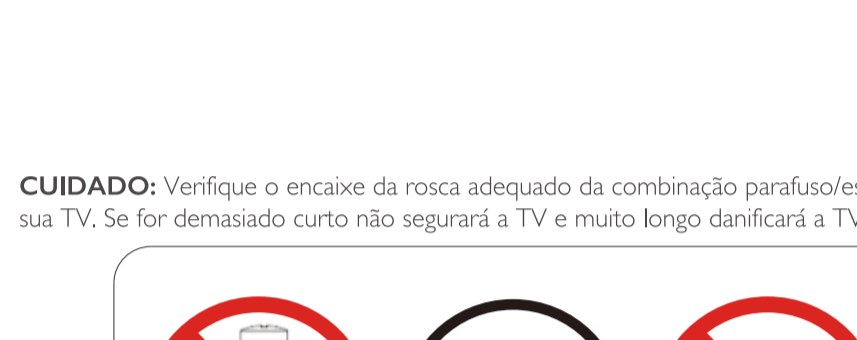

5. Final assembly

- The flat panel must be lifted carefully by two people in order to attach it to the wall mount you just installed.
- Hang both arms by aligning the top and bottom hooks on the horizontal rails of the mount.



Instalação padrão do suporte da tela plana

4. Se a tela plana tem irregularidades na parte traseira ou recesso nos pontos de montagem, os espaçadores devem ser colocados entre o braço de suporte e a tela plana para compensar a diferença de profundidade.



Tela com irregularidades na parte traseira ou recesso nos pontos de montagem

4. Se a tela plana tem irregularidades na parte traseira ou recesso nos pontos de montagem, os espaçadores devem ser colocados entre o braço de suporte e a tela plana para compensar a diferença de profundidade.



2.91inch collapsed

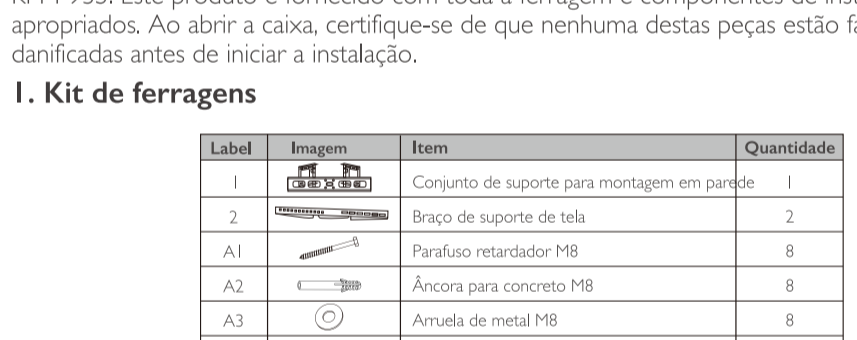
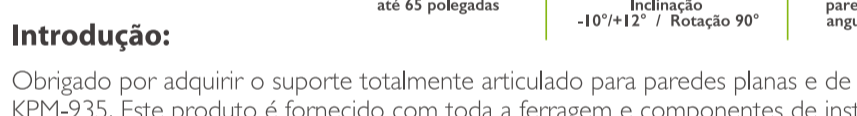

20inch fully extended

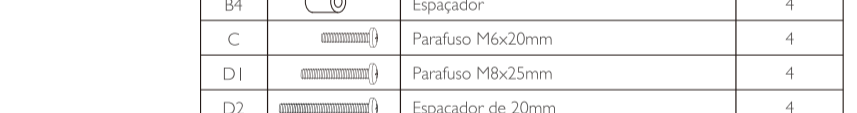

2.91inch collapsed

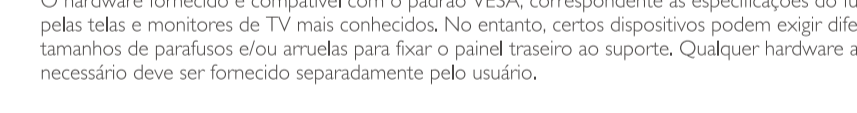

20inch fully extended



2.91inch collapsed



20inch fully extended



2.91inch collapsed

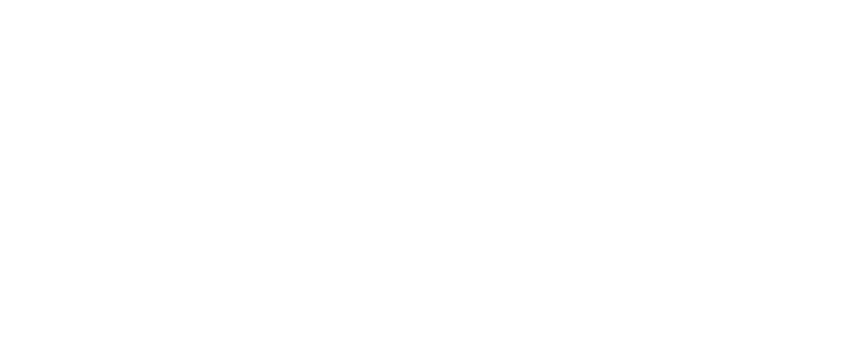

20inch fully extended



2.91inch collapsed

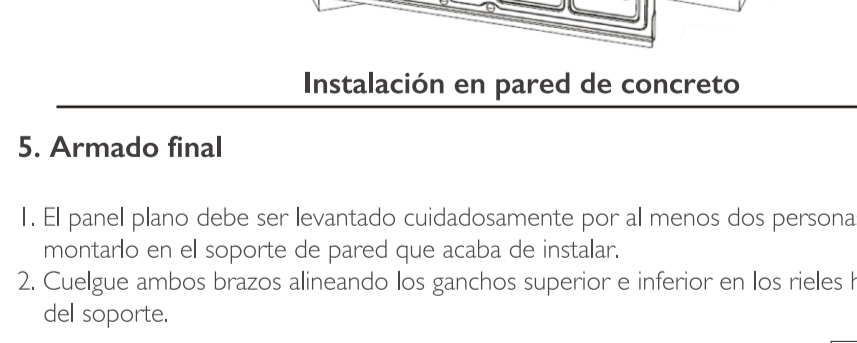
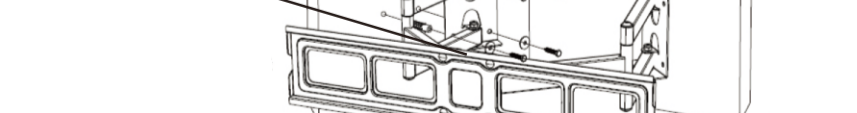

20inch fully extended



2.91inch collapsed

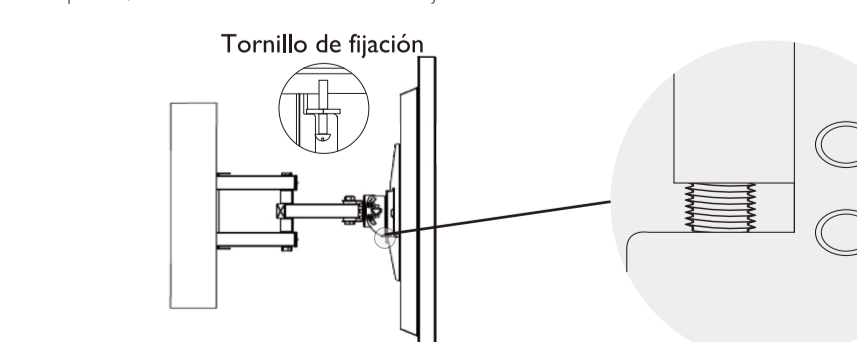
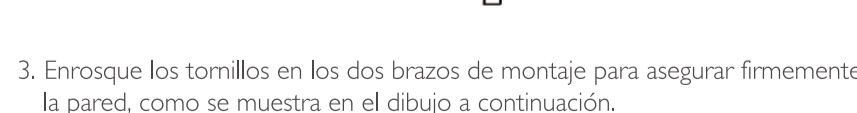

20inch fully extended



2.91inch collapsed



20inch fully extended



2.91inch collapsed



20inch fully extended



2.91inch collapsed



20inch fully extended



2.91inch collapsed



20inch fully extended



2.91inch collapsed



20inch fully extended



2.91inch collapsed



20inch fully extended



2.91inch collapsed



20inch fully extended



2.91inch collapsed



20inch fully extended



2.91inch collapsed



20inch fully extended



2.91inch collapsed



20inch fully extended



2.91inch collapsed



20inch fully extended



2.91inch collapsed



20inch fully extended



2.91inch collapsed



20inch fully extended



2.91inch collapsed



20inch fully extended



2.91inch collapsed



20inch fully extended



2.91inch collapsed



20inch fully extended



2.91inch collapsed



20inch fully extended



2.91inch collapsed

